



TRIPLE FOG LIGHT KIT (2017+ FORD RAPTOR)



KIT CONTENTS:

- (2) STAINLESS STEEL BRACKETS (DRIVER & PASSENGER)
- (2) M6 BOLTS & M6 FLANGE LOCKNUTS
- (2) M8 BOLTS & M8 FLANGE LOCKNUTS
- (2) INSTRUCTIONS
- (1) WIRING HARNESS (optional—included with full light kit)

TRIPLE FOG LIGHT KIT (2017+ FORD RAPTOR)



1. LOOSEN & REMOVE BOLTS

There are 2 bolts holding a support rod to the vehicle. Loosen the inner bolt and remove the outer bolt. You will also need to remove the clip-on nut as well.

2. INSTALL BRACKETS

Insert the appropriate bracket (the driver's side bracket is labeled) and secure to the vehicle using the provided M8 nut/bolt and a M6 nut/bolt. The M8 nut/bolt will go on the outer hole (where the factory nut/bolt were removed from). Be sure to pass the bolt through the support rod (the support rod will sit on top of the bracket). The M6 nut/bolt will use an existing hole towards the inner side of the bracket.

Be sure to put the nuts on the backside of the bumper (the bolts will go towards the front of the truck) and tighten then just enough so that it holds the bracket in place but allows you to move the entire bracket up/down. You'll want the bracket loose so that you can align your lights vertically after they are installed.

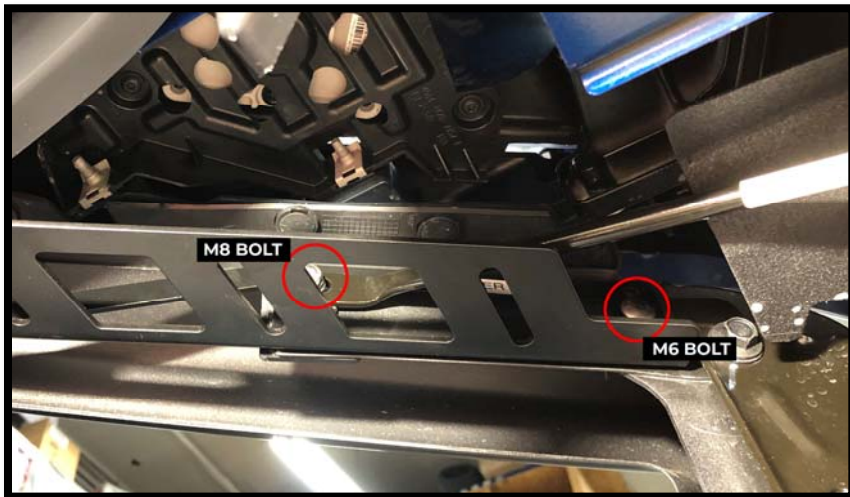

3. TIGHTEN SUPPORT ROD BOLT

Re-tighten the support rod's inner nut/bolt (which was loosened in Step 1).

TRIPLE FOG LIGHT KIT (2017+ FORD RAPTOR)



4. ADJUST LIGHT BEZELS/LENSES

Your lights will be mounted upside down (that is, hanging from the brackets). Most lights will still function properly however the logo may be upside down. You may want to remove your lights bezel and rotate them 180° (if removeable). If your lights have a combination lens (such as the Baja Designs Driving/Combo) you'll want to rotate the lens as well so that the spot pattern is on top and the wide cornering pattern is on the bottom. This photo shows a Rigid Industries SAE light. The particular light will function properly however the logo will be upside down.

Depending on which lights you order, extension brackets may be available that will allow you to hang the lights in an up-right manor.



5. INSTALL LIGHT BRACKETS

Pay close attention to the way you mount your lights brackets. You'll want to position the light brackets as follows (Rigid Industries D-Series on the left and Baja Designs on the right). Installing your lights in this manor will allow you tilt the lights up/down.

TRIPLE FOG LIGHT KIT (2017+ FORD RAPTOR)



6. MOUNT LIGHTS

You'll now mount your lights to the triple fog light bracket. Use the supplied hardware that came with your lights (or included in this kit). Tighten the bolts on the light brackets just enough so that you can still move them left/right/forward/back which will allow you to align your light pattern properly.

Also adjust the entire assembly up/down in your bumper opening. Once your entire assembly is centered in the opening tighten down the triple fog light bracket bolts so that the entire assembly does not move (leave the lights loose still so you can adjust their pattern).



7. CONNECT WIRING HARNESS

If included in your kit, route your harness to your lights and plug in the connectors. Your harness may be labeled (A, B, C) to help you identify which pairs of lights connect together. If your harness is not labeled you can look for the colored wires by the connector to help identify which pairs go together.

If your lights feature a backlight option (such as the Rigid Radiance) you'll want to connect the control wire (the single wire next to the connector) to your lights backlight wire.

Some harnesses have a DT connector with a control wire attached (Rigid D-Series) while some harnesses have 3 wires (Rigid Radiance).

Connect the **Black** wire on the harness, to the **Black** wire on the light.

Connect the **Blue, Red or Green** wire on the harness, to the **Red** wire on the light.

Connect the **Tan** wire on the harness, to the **White** wire on the light. (This is your backlight control wire)

TRIPLE FOG LIGHT KIT (2017+ FORD RAPTOR)

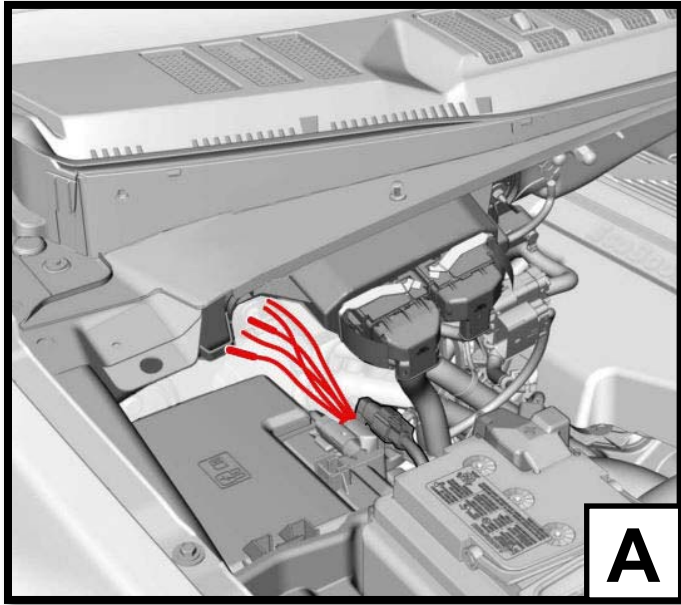

8. UPFITTER SWITCH WIRING

You will find two sets of wires for your upfitters. One set are **hot** and lead to the upfitters while the other side are passthrough wires (they just go into the cabin for future use).

Please refer to the diagrams on the left for your particular vehicles **hot** upfitter wire locations (Figure A is for 2017 Raptors and figure B is for 2018+ Raptors).

You'll want to strip back a portion of the desired upfitter wire and crimp it onto the desired wire connector on the fog light harness.

The ground cable can be secured to a grounding point within the engine bay (there is a nut to the left of the upfitter wires you can utilize).

Refer to the chart on the following page to determine the amperage loads for each upfitter.

Once everything is connected flip your upfitters on and adjust your lights up/down/left/right. Don't forget to tighten the bolts on your lights to ensure they do not move once aligned properly.

DO NOT EXCEED THE MAXIMUM AMPERAGE LOADS FOR AN UPFITTER

Baja Designs S1 (Pair): 2.9 Amps Max

Baja Designs S2 Sport (Pair): 1.8 Amps Max

Baja Designs S2 Pro (Pair): 3.32 Amps Max

Baja Designs Squadron Sport (Pair): 4.0 Amps Max

Baja Designs Squadron Pro (Pair): 6.66 Amps Max

Rigid Industries D-Series Driving (Pair): 6.28 Amps Max

Rigid Industries D-Series SAE (Pair): 3.0 Amps Max

Rigid Industries D-Series (All Others, Pair): 4.28 Amps Max

Rigid Industries Radiance Pod (Pairs): 2.0 Amps Max

Rigid Industries Radiance Scene (Pairs): 4.0 Amps Max

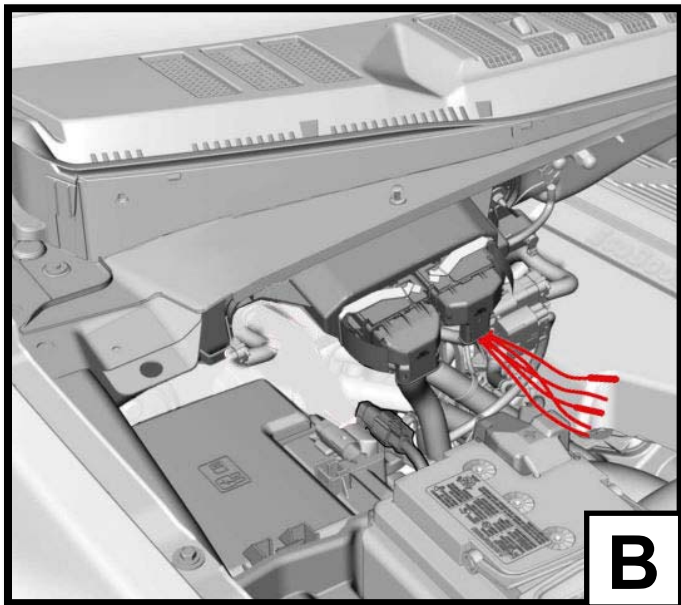

TRIPLE FOG LIGHT KIT (2017+ FORD RAPTOR)

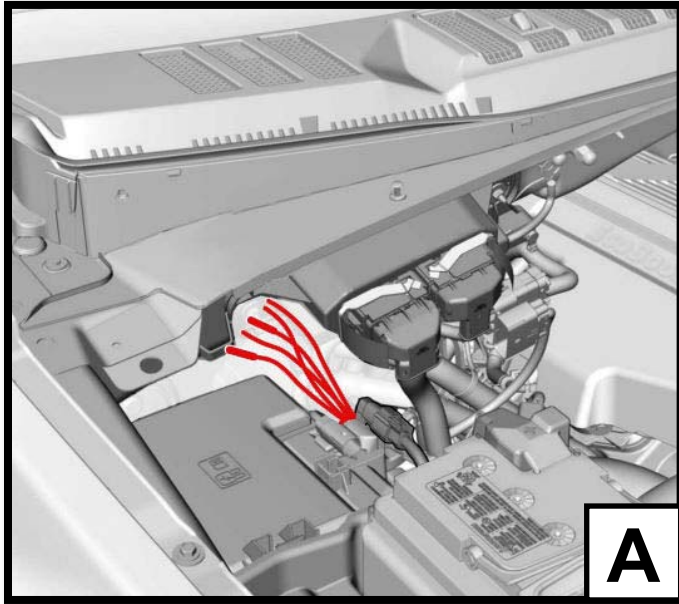

A

2017 WIRE CHART (fig. A)

| <u>SWITCH</u> | <u>MAX AMPERAGE</u> | <u>WIRE COLOR</u> |
|---------------|---------------------|-------------------|
| Aux 1 | 15 Amp | Green/Blue |
| Aux 2 | 15 Amp | Gray/Yellow |
| Aux 3 | 10 Amp | Violet/Orange |
| Aux 4 | 10 Amp | Brown/Blue |
| Aux 5 | 5 Amp | Gray/Orange |
| Aux 6 | 5 Amp | Yellow/Violet |

2018-2019 WIRE CHART (fig. B)

| <u>SWITCH</u> | <u>MAX AMPERAGE</u> | <u>WIRE COLOR</u> |
|---------------|---------------------|-------------------|
| Aux 1 | 15 Amp | Green/White |
| Aux 2 | 15 Amp | Brown/Blue |
| Aux 3 | 10 Amp | Gray/Yellow |
| Aux 4 | 10 Amp | Yellow/Green |
| Aux 5 | 5 Amp | Brown/White |
| Aux 6 | 5 Amp | Green/Orange |

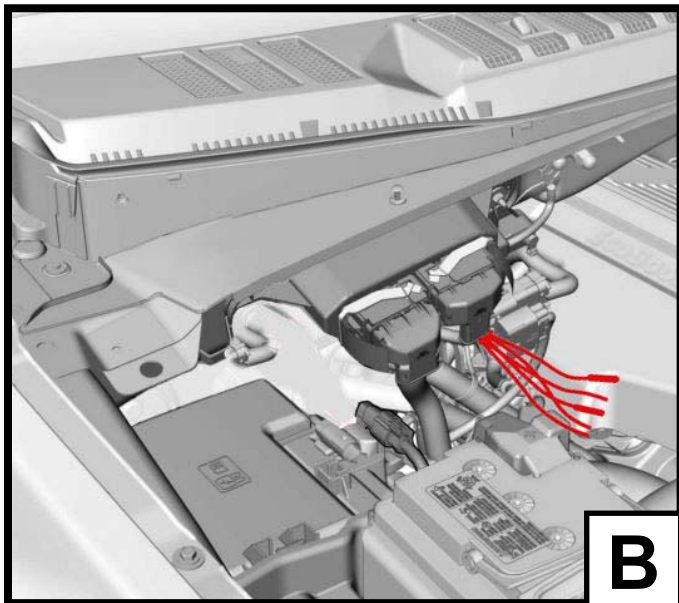

B

2020 WIRE CHART (fig. B)

| <u>SWITCH</u> | <u>MAX AMPERAGE</u> | <u>WIRE COLOR</u> |
|---------------|---------------------|-------------------|
| Aux 1 | 15 Amp | Yellow |
| Aux 2 | 15 Amp | Green/Brown |
| Aux 3 | 10 Amp | Violet/Green |
| Aux 4 | 10 Amp | Brown |
| Aux 5 | 5 Amp | Blue/Orange |
| Aux 6 | 5 Amp | Yellow/Orange |